

Function fittings

Series TECNOFUN



New compact line of different logic functions that can be used in any place of the secondary pneumatic circuit, developed to be installed directly onto the main pneumatic components (distributors or cylinders).

Thanks to the modular design it is possible to easily join together multiple logic functions without the need of using pipes to connect them; it is also possible to choose the type and style of each connection. The connections available are the following: straight cartridge; Banjo PL cartridge; male cartridge threaded 1/8" or 1/4" and female cartridge threaded 1/8". Function fittings can also be assembled side by side in order to be assembled on the DIN EN 50022 rail (using the relevant kit).

Technical sheet

FLUIDS		Compressed air (for different fluid please contact our Technical Dept.)
APPLICATIONS		Pneumatic circuits according to DIN 3861-3870 norms.
SUGGESTED TUBES		TPU (Polyurethane), PA11/PA12 (Polyamide), TPE (Polyethylene), TPA (Polyurethane/Copolyester)
TUBES TOLERANCES		Diam. between 4 and 10 mm +/- 0,05 Diam. from 12 mm +/- 0,1
TEMPERATURE AND PRESSURE		Temperatures and pressures usually depend by the technical features of the employed tubes, for more complete informations please read the technical catalogue of your tube supplier.
THREAD TYPE		BSP parallel UNI-ISO 228
MATERIALS	Main body	IXEF 1022, technopolymer glass-fiber reinforced
	Fitting body, sleeve, collar and back ring	POM copolymer ISO1043-1
	Adjustment screw and fitting	Brass UNI EN 12164 CW614N
	Cartridge body	Aluminium
	Spring	Stainless steel AISI 301 austenitic
	Seals	NBR 70 DWGV-EN549 UL157

Additional technical informations

Input/output connection directly integrated into the body
In line or 90° connection
Possibility to build a manifold -parallel mounting-
Different connection options: - Tube Ø4 Ø6 Ø8 (elbow version as well) - G1/8" G1/4" male straight cartridge - G1/8" female cartridge, in line or 90°
Different mounting options: - Wall fixing through the holes in the body - By means of the fixing bracket - Panel mounting (for those function that include such possibility) - On DIN rail EN 50022 (using the DIN rail adapter kit)

Available functions:

- Flow control valve (FCV)
- Pressure regulator (PR)
- Block valve (BV)
- Quick exhaust valve (QEV)
- OR gate (CSV-OR)
- AND gate (CSV-AND)
- Pressure gauge (PI)
- Pressure regulator + pressure gauge (PR+PI)
- Block valve + Flow control valve (BV+FCV)
- Block valve + quick exhaust valve (BV+QEV)

ART. 551.11T.A.B.XX

Flow regulator

TYPE

T	1 = Unidirectional 2 = Bidirectional
A	Connection A - see connections list
B	Connection B - see connections list

SEE CONNECTIONS LIST

00	= None
D4	= Straight Ø4
D6	= Straight Ø6
D8	= Straight Ø8
L1	= Female banjo G1/8"
G4	= Rotating banjo Ø4
G6	= Rotating banjo Ø6
G8	= Rotating banjo Ø8
M1	= G1/8" male
M2	= G1/4" male
F1	= G1/8" female

Note

Example: 551.111.D6.D6.XX
Flow control valve unidirectional, connections "A" and "B" Tube Ø6.
For the dimension including cartridges see page Accessories - Function fittings

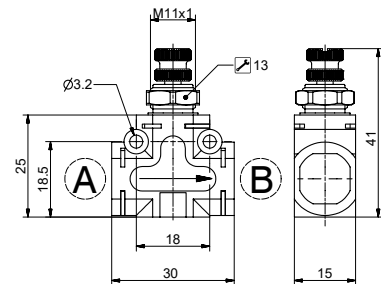

Technical characteristics

- The flow control valve is normally used to regulate the air flow and, as a consequence, for example, the speed of a cylinder. Two types of flow control valves are available: unidirectional and bidirectional.
- In the unidirectional valve the flow is regulated only in one direction while is free to move in the opposite direction; in the bidirectional valve the flow is regulated in both directions.
- Panel mounting using the lock nut supplied as standard.
- On DIN rail using the relevant adaptor kit (see accessories).
- With 90° bracket (see accessories).
- Directly on the support plate thanks to two through holes on the body.

Technical characteristics

- Fluid: **Filtered and lubricated air or non**
- Working ports size: **see connections list**
- Max working pressure: **10 bar**
- Temperature: **-5 °C ... + 50 °C**
- Weight: **26 g**
- Orifice size: **Ø3 mm**
- Free exhaust flow rate in the opposite side of the regulation: **800 NI/min (for unidirectional version)**

Flow rates curves 6 bar

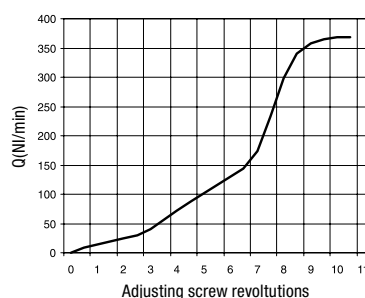

Pneumatic symbols

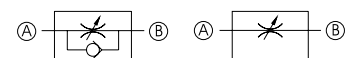

ART. 551.12T.A.B.XX

In line pressure regulator

TYPE

T	2 = 0 - 2 bar
	4 = 0 - 4 bar
	8 = 0 - 8 bar
A	Connection A - see connections list
B	Connection B - see connections list

SEE CONNECTIONS LIST

00	= None
D4	= Straight Ø4
D6	= Straight Ø6
D8	= Straight Ø8
L1	= Female banjo G1/8"
G4	= Rotating banjo Ø4
G6	= Rotating banjo Ø6
G8	= Rotating banjo Ø8
M1	= G1/8" male
M2	= G1/4" male
F1	= G1/8" female

Note

Example: 551.128.D8.D8.XX
In line pressure regulator, pressure range (bar) 0-8 bar. Connections "A" and "B" Tube Ø8.
For the dimension including cartridges see page Accessories - Function fittings

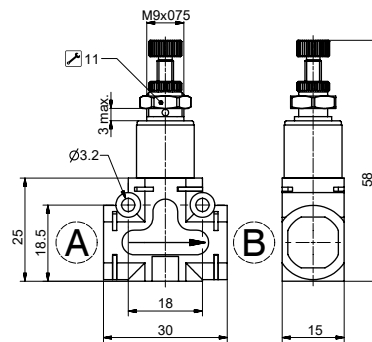

Technical characteristics

- The pressure regulator is a device which is used to reduce, regulate and stabilize their pressure in a conduit in order to adapt it to the needs of the equipments to be supplied. The pressure regulator incorporates the relieving function.
- Panel mounting using the lock nut supplied as standard.
- On DIN rail using the relevant adaptor kit (see accessories).
- With 90° bracket (see accessories).
- Directly on the support plate thanks to two through holes on the body.

Technical characteristics

- Fluid: **Filtered and lubricated air or non**
- Working ports size: **see connections list**
- Max working pressure: **10 bar**
- Temperature: **-5 °C ... + 50 °C**
- Weight: **31 g**
- Flow rate at 6 bar with Δp=1 (NI/min): **180 NI/min**
- Pressure range: **0 ... 2 / 0 ... 4 / 0 ... 8 bar**

Pneumatic symbols

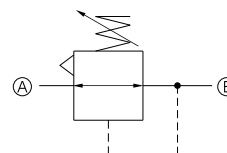

ART. 551.22T.A.B.XX

90° pressure regulator

TYPE

T	2 = 0 - 2 bar
	4 = 0 - 4 bar
	8 = 0 - 8 bar
A	Connection A - see connections list
B	Connection B - see connections list

SEE CONNECTIONS LIST

00	= None
D4	= Straight Ø4
D6	= Straight Ø6
D8	= Straight Ø8
L1	= Female banjo G1/8"
G4	= Rotating banjo Ø4
G6	= Rotating banjo Ø6
G8	= Rotating banjo Ø8
M1	= G1/8" male
M2	= G1/4" male
F1	= G1/8" female

Note

Example: 551.224.M1.D6.XX
90° pressure regulator, pressure range (bar) 0 - 4 bar. Connections "A" Male G1/8 and "B" Tube Ø6.
For the dimension including cartridges see page Accessories - Function fittings

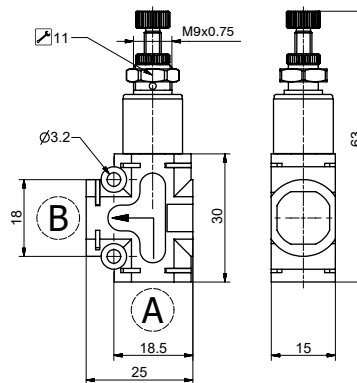

Technical characteristics

- The pressure regulator is a device which is used to reduce, regulate and stabilize the air pressure in a conduit in order to adapt it to the needs of the equipments to be supplied. The pressure regulator incorporates the relieving function.
- Panel mounting using the lock nut supplied as standard.
- On DIN rail using the relevant adaptor kit (see accessories).
- On DIN rail using the relevant adaptor kit (see accessories).
- Directly on the support plate thanks to two through holes on the body.

Technical characteristics

- Fluid: **Filtered and lubricated air or non**
- Working ports size: **see connections list**
- Max working pressure: **10 bar**
- Temperature: **-5 °C ... + 50 °C**
- Weight: **31 g**
- Flow rate at 6 bar with Δp=1 (NI/min): **180 NI/min**
- Pressure range: **0 ... 2 / 0 ... 4 / 0 ... 8 bar**

Pneumatic symbols

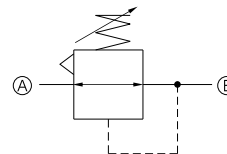

ART. **551.13T.A.B.XX**

Blocking valve

TYPE

T	1 = Unidirectional 2 = Bidirectional
A	Connection A - see connections list
B	Connection B - see connections list

SEE CONNECTIONS LIST

00	= None
D4	= Straight Ø4
D6	= Straight Ø6
D8	= Straight Ø8
L1	= Female banjo G1/8"
G4	= Rotating banjo Ø4
G6	= Rotating banjo Ø6
G8	= Rotating banjo Ø8
M1	= G1/8" male
M2	= G1/4" male
F1	= G1/8" female

Note:

Example: 551.131.D4.D4.XX
In line blocking valve, unidirectional.
Connections "A" and "B" Tube Ø4.
For the dimension including cartridges see
page Accessories - Function fittings

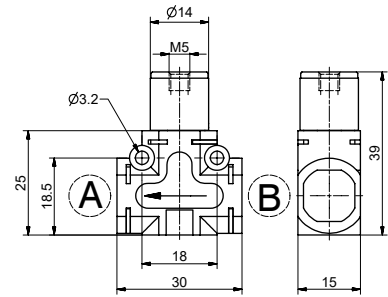

Technical characteristics

- The blocking valve function is to maintain the circuit downstream pressure in the event of loss of supply pressure. It is normally fitted directly onto the cylinder connections ports in order to ensure that, in case of accidental loss of the supply pressure, the units positions is maintained. This is achieved as the blocking valve preserves the pressure inside the pressurised chamber. Blocking valves can be unidirectional or bidirectional.
- In the unidirectional version the air flow is free in one direction while in order to allow the flow in the opposite direction is necessary to send a pneumatic signal to the unit connection 12.
- The bidirectional version requires a pneumatic signal on connection 12 to allow the flow in any of the two directions.
- On DIN rail using the relevant adaptor kit (see accessories).
- With 90° bracket (see accessories).
- Directly on the support plate thanks to two through holes on the body.

Technical characteristics

- Fluid: **Filtered and lubricated air or non**
- Working ports size: **see connections list**
- Working pressure: **0,5 ... 10 bar**
- Temperature: **-5 °C ... + 50 °C**
- Weight: **26 g**
- Flow rate at 6 bar with $\Delta p=1$ (NI/min): **285 NI/min**
- Flow rate at 6 bar with free exhaust: **450 NI/min**

Piloting curves

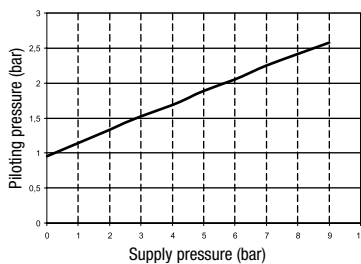

Pneumatic symbols

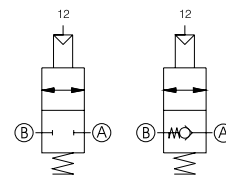

ART. 551.23T.A.B.XX

90° blocking valve

TYPE

T	1 = Unidirectional 2 = Bidirectional
A	Connection A - see connections list
B	Connection B - see connections list

SEE CONNECTIONS LIST

00	None
D4	Straight Ø4
D6	Straight Ø6
D8	Straight Ø8
L1	Female banjo G1/8"
G4	Rotating banjo Ø4
G6	Rotating banjo Ø6
G8	Rotating banjo Ø8
M1	G1/8" male
M2	G1/4" male
F1	G1/8" female

Note:

Example: 551.231.D6.M1.XX
90° blocking valve. Connections "A" Male G1/8 and "B" Tube Ø6.
For the dimension including cartridges see page Accessories - Function fittings

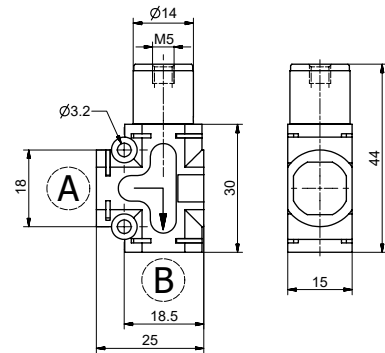

Technical characteristics

- The blocking valve function is to maintain the circuit downstream pressure in the event of loss of supply pressure. It is normally fitted directly onto the cylinder connections ports in order to ensure that, in case of accidental loss of the supply pressure, the units positions is maintained. This is achieved as the blocking valve preserves the pressure inside the pressurised chamber.
- Unidirectional and bidirectional version are both available.
- In the unidirectional version the air flow is free in one direction while in order to allow the flow in the opposite direction is necessary to send a pneumatic signal to the unit connection 12.
- The bidirectional version requires a pneumatic signal on connection 12 to allow the flow in any of the two directions.
- On DIN rail using the relevant adaptor kit (see accessories)
- With 90° bracket (see accessories).
- Directly on the support plate thanks to two through holes on the body.

Technical characteristics

- Fluid: **Filtered and lubricated air or non**
- Working ports size: **see connections list**
- Working pressure: **0,5 ... 10 bar**
- Temperature: **-5 °C ... + 50 °C**
- Weight: **26 g**
- Flow rate at 6 bar with $\Delta p=1$ (NI/min): **285 NI/min**
- Flow rate at 6 bar with free exhaust: **450 NI/min**

Piloting curves

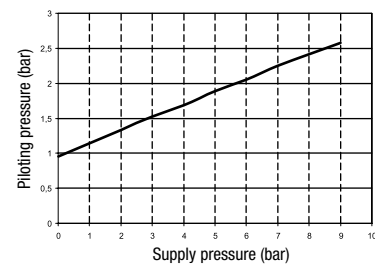

Pneumatic symbols

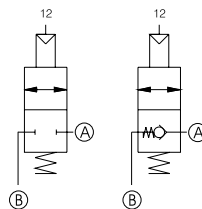

ART. 551.141.A.B.C

Circuit selector valve-OR

TYPE

A	Connection A - see connections list
B	Connection B - see connections list
C	Connection C - see connections list

SEE CONNECTIONS LIST

00	None
D4	Straight Ø4
D6	Straight Ø6
D8	Straight Ø8
L1	Female banjo G1/8"
G4	Rotating banjo Ø4
G6	Rotating banjo Ø6
G8	Rotating banjo Ø8
M1	G1/8" male
M2	G1/4" male
F1	G1/8" female

Note

Example: 551.141.D8.D8.D8
Circuit selector valve - OR.
Connections "A", "B" and "C" Tube Ø8.
For the dimension including cartridges see page Accessories - Function fittings

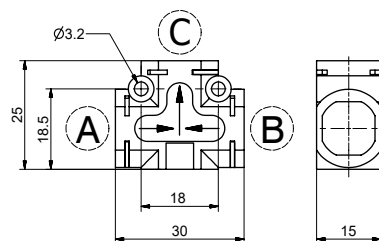

Technical characteristics

- These valves have two inlets and one output connection and are normally called high pressure selector valves as, when receiving two separate pressure supply, only allow the passage of the highest pressure. The most common application is to operate a component from two separate positions.
- On DIN rail using the relevant adaptor kit (see accessories).
- With 90° bracket (see accessories).
- Directly on the support plate thanks to two through holes on the body.

Technical characteristics

- Fluid: **Filtered and lubricated air or non**
- Working ports size: **see connections list**
- Max working pressure: **10 bar**
- Temperature: **-5 °C ... + 50 °C**
- Weight: **10 g**
- Flow rate at 6 bar with $\Delta p=1$ (NI/min): **600 NI/min**

Pneumatic symbols

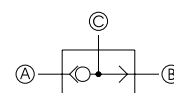

ART. **551.151A.B.C**

Circuit selector valve-AND

TYPE

A	Connection A - see connections list
B	Connection B - see connections list
C	Connection C - see connections list

SEE CONNECTIONS LIST

00	= None
D4	= Straight Ø4
D6	= Straight Ø6
D8	= Straight Ø8
L1	= Female banjo G1/8"
G4	= Rotating banjo Ø4
G6	= Rotating banjo Ø6
G8	= Rotating banjo Ø8
M1	= G1/8" male
M2	= G1/4" male
F1	= G1/8" female

Note

Example: 551.151.D6.D6.D6
Circuit selector valve AND.
Connections "A", "B" and "C" Tube Ø6.
For the dimension including cartridges see page Accessories - Function fittings

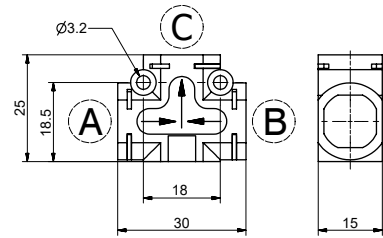

Technical characteristics

- These valves have two inlets and one output connection and are normally called low pressure selector valves as, when receiving two separate pressure supply, only allow the passage of the lowest pressure. The most common application is to operate a component from two separate positions.
- On DIN rail using the relevant adaptor kit (see accessories).
- With 90° bracket (see accessories).
- Directly on the support plate thanks to two through holes on the body.

Technical characteristics

- Fluid: **Filtered and lubricated air or non**
- Working ports size: **see connections list**
- Max working pressure: **10 bar**
- Temperature: **-5 °C ... + 50 °C**
- Weight: **10 g**
- Flow rate at 6 bar with $\Delta p=1$ (NI/min): **550 NI/min**

Pneumatic symbols

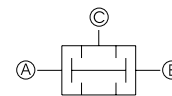

ART. **551.161.A.B.XX**

Quick exhaust valve

TYPE

A	Connection A - see connections list
B	Connection B - see connections list

SEE CONNECTIONS LIST

00	= None
D4	= Straight Ø4
D6	= Straight Ø6
D8	= Straight Ø8
L1	= Female banjo G1/8"
G4	= Rotating banjo Ø4
G6	= Rotating banjo Ø6
G8	= Rotating banjo Ø8
M1	= G1/8" male
M2	= G1/4" male
F1	= G1/8" female

Note

Example: 551.161.D8.D8.XX
Quick exhaust valve. Connections "A"
and "B" Tube Ø8.
For the dimension including cartridges see
page Accessories - Function fittings

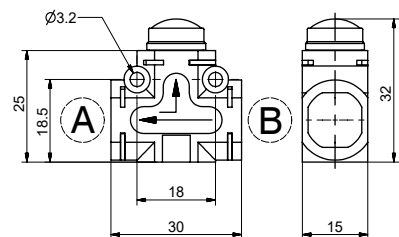

Technical characteristics

- These are 3 ways, two positions valves which can be directly mounted onto the actuator or between the actuator and the control valve. Their function is to discharge the air directly into the atmosphere without going through the pneumatic circuit enabling the actuator to reach the maximum speed.
- On DIN rail using the relevant adaptor kit (see accessories).
- With 90° bracket (see accessories).
- Directly on the support plate thanks to two through holes on the body.

Technical characteristics

- Fluid: **Filtered and lubricated air or non**
- Working ports size: **see connections list**
- Max working pressure: **10 bar**
- Temperature: **-5 °C ... + 50 °C**
- Weight: **15 g**
- Flow rate at 6 bar with $\Delta p=1$ (NI/min): **250 NI/min**
- Flow rate at 6 bar with free exhaust (NI/min): **500 NI/min**

Pneumatic symbols

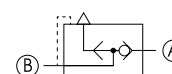

ART. 551.178.A.B.XX

Pressure indicator

TYPE

- A** Connection A - see connections list
- B** Connection B - see connections list

SEE CONNECTIONS LIST

- 00** = None
- D4** = Straight Ø4
- D6** = Straight Ø6
- D8** = Straight Ø8
- L1** = Female banjo G1/8"
- G4** = Rotating banjo Ø4
- G6** = Rotating banjo Ø6
- G8** = Rotating banjo Ø8
- M1** = G1/8" male
- M2** = G1/4" male
- F1** = G1/8" female

Note

Example: 551.178.D6.D4.XX
Pressure indicator. Connections "A" Tube Ø6, "B" Tube Ø4.
For the dimension including cartridges see page Accessories - Function fittings

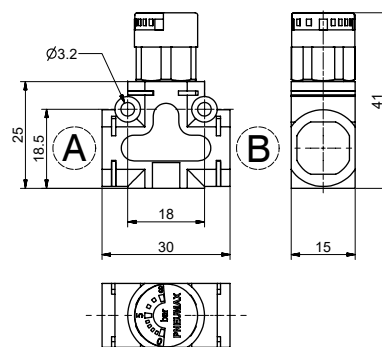

Technical characteristics

- The pressure visual indicator is a device which measures the pressure inside a pneumatic circuit. The 0 to 8 bar visual indicator makes very easy to monitor the pressure state inside the circuit. It can be use on its own or can be coupled with another device.
- It can be use on its own or can be coupled with another device.
- On DIN rail using the relevant adaptor kit (see accessories)
- With 90° bracket (see accessories)
- Directly on the support plate thanks to two through holes on the body

Technical characteristics

- Fluid: **Filtered and lubricated air or non**
- Working ports size: **see connections list**
- Max working pressure: **8 bar**
- Temperature: **-5 °C ... + 50 °C**
- Weight: **20,5 g**
- Visualization scale: **0 - 8 bar**

Pneumatic symbols

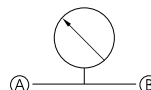

ART. 551.181A.B.XX

In line progressive start-up valve

TYPE

- A** Connection A - see connections list
- B** Connection B - see connections list

SEE CONNECTIONS LIST

- 00** = None
- D4** = Straight Ø4
- D6** = Straight Ø6
- D8** = Straight Ø8
- L1** = Female banjo G1/8"
- G4** = Rotating banjo Ø4
- G6** = Rotating banjo Ø6
- G8** = Rotating banjo Ø8
- M1** = G1/8" male
- M2** = G1/4" male
- F1** = G1/8" female

Note

Example: 551.181.D6.D4.XX
In line progressive start-up valve.
Connections "A" Tube Ø6, "B" Tube Ø4.
For the dimension including cartridges see page Accessories - Function fittings

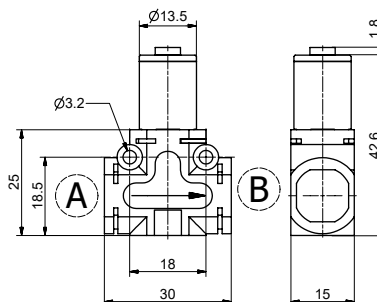

Technical characteristics

- The soft start valve is a device designed to gradually pressurise the downstream circuit until 50% of the upstream pressure value is reached.
- Once the 50% of the upstream pressure value is reached in the down stream circuit the valve fully opens allowing full air passage.
- The filling time can be adjusted thanks to the built in flow regulator.
- This device is used in order to ensure that during the pneumatic circuit start up the cylinders will return to theirs home position slowly avoiding collisions or sudden movements.

Technical characteristics

- Fluid: **Filtered and lubricated air or non**
- Working ports size: **see connections list**
- Opening pressure (Pa): **50% of the inlet pressure (Pe)**
- Flow rate at 6 bar with free exhaust (NI/min) from 1 to 2 with opening circuit: **350 NI/min**
- Flow rate at 6 bar with $\Delta p=1$ from 1 to 2 with opening circuit: **600 NI/min**
- Flow rate at 6 bar with $\Delta p=1$ from 2 to 1 with opening pin: **650 NI/min**
- Temperature: **-5 °C ... + 50 °C**
- Weight: **31 g**

Pneumatic symbols

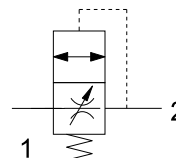

Piloting curves

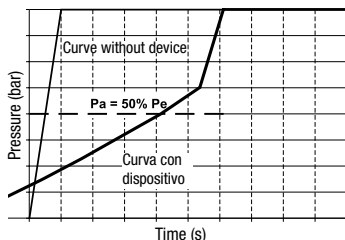

Adjustment curve

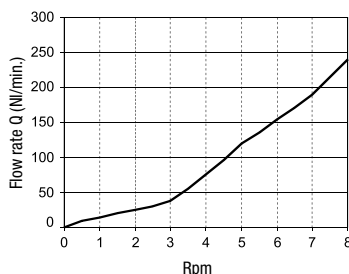

ART. **551.281A.B.XX**

90° progressive start-up valve

TYPE

A	Connection A - see connections list
B	Connection B - see connections list

SEE CONNECTIONS LIST

00	= None
D4	= Straight Ø4
D6	= Straight Ø6
D8	= Straight Ø8
L1	= Female banjo G1/8"
G4	= Rotating banjo Ø4
G6	= Rotating banjo Ø6
G8	= Rotating banjo Ø8
M1	= G1/8" male
M2	= G1/4" male
F1	= G1/8" female

Note

Example: 551.281.M1.D4.XX
90° progressive start-up valve. Connections "A" Male G1/8", "B" Tube Ø4.
For the dimension including cartridges see page Accessories - Function fittings

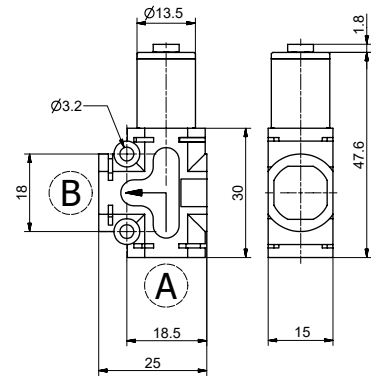

Technical characteristics

- The soft start valve is a device designed to gradually pressurise the downstream circuit until 50% of the upstream pressure value is reached.
- Once the 50% of the upstream pressure value is reached in the down stream circuit the valve fully opens allowing full air passage.
- The filling time can be adjusted thanks to the built in flow regulator.
- This device is used in order to ensure that during the pneumatic circuit start up the cylinders will return to theirs home position slowly avoiding collisions or sudden movements.

Technical characteristics

- Fluid: **Filtered and lubricated air or non**
- Working ports size: **see connections list**
- Opening pressure (Pa): **50% of the inlet pressure (Pi)**
- Flow rate at 6 bar with free exhaust (NI/min) from 1 to 2 with opening circuit: **350 NI/min**
- Flow rate at 6 bar with $\Delta p=1$ from 1 to 2 with opening circuit: **600 NI/min**
- Flow rate at 6 bar with $\Delta p=1$ from 2 to 1 with opening pin: **650 NI/min**
- Temperature: **-5 °C ... + 50 °C**
- Weight: **31 g**

Piloting curves

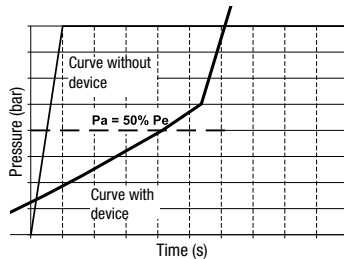

Adjustment curve

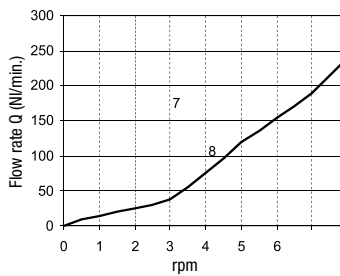

Pneumatic symbols

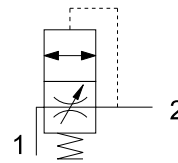

ART. 551.1FT.A.B.XX

In line blocking valve with flow control valve

TYPE

T	1 = Unidirectional blocking valve + unidirectional flow control valve
	2 = Bidirectional blocking valve + bidirectional flow control valve
	3 = Unidirectional blocking valve + bidirectional flow control valve
	4 = Bidirectional blocking valve + unidirectional flow control valve
A	Connection A - see connections list
B	Connection B - see connections list

SEE CONNECTIONS LIST

00 = None
D4 = Straight Ø4
D6 = Straight Ø6
D8 = Straight Ø8
L1 = Female banjo G1/8"
G4 = Rotating banjo Ø4
G6 = Rotating banjo Ø6
G8 = Rotating banjo Ø8
M1 = G1/8" male
M2 = G1/4" male
F1 = G1/8" female

Note

Example: 551.1F1.00.00.XX
In line blocking valve + flow control valve.
Without connections "A" and "B".
For the dimension including cartridges
see page Accessories - Function fittings

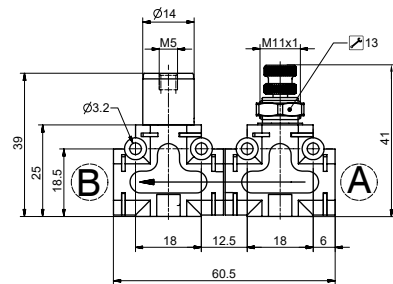
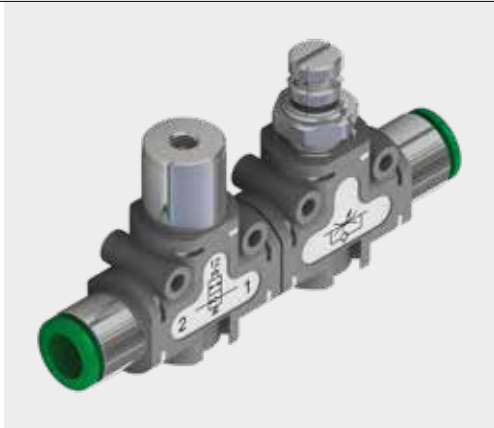

Technical characteristics

- The combination of this two functions ensures that the downstream pressure is maintained in case of accidental loss of supply pressure and at the same time grants the possibility to regulate the circuit flow rate. A typical application of this combination is close to or directly assembled onto the actuator connection ports. This allows to keep pressurised the cylinder chamber in case of accidental loss of supply pressure and to regulate the exhaust flow rate when the blocking valve is actuated.
- The possible combinations are the following:
 - Unidirectional blocking valve + unidirectional flow control valve
 - Bidirectional blocking valve + bidirectional flow control valve
 - Bidirectional blocking valve + unidirectional flow control valve
 - Unidirectional blocking valve + bidirectional flow control valve

Technical characteristics

- Fluid: **Filtered and lubricated air or non**
- Working ports size: **see connections list**
- Max working pressure: **0,5 ... 10 bar**
- Temperature: **-5 °C ... + 50 °C**
- Orifice size: **Ø3 mm**
- Flow rate at 6 bar with Δp=1 (NI/min): **285 NI/min**
- Weight: **62 g**

Piloting pressure

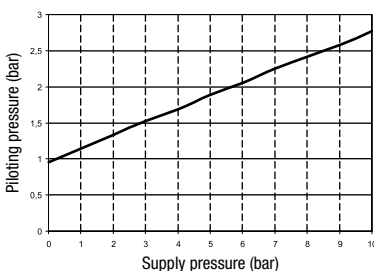

Pneumatic symbols

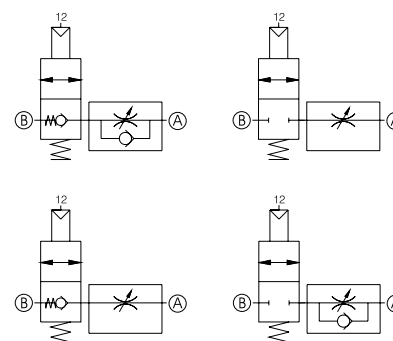

ART. **551.2FT.A.B.XX**

90° blocking valve + flow control valve

TYPE

T	1 = 90° unidirectional blocking valve + unidirectional flow control valve
	2 = 90° bidirectional blocking valve + bidirectional flow control valve
	3 = 90° unidirectional blocking valve + bidirectional flow control valve
	4 = 90° bidirectional blocking valve + unidirectional flow control valve
A	Connection A - see connections list
B	Connection B - see connections list

SEE CONNECTIONS LIST

00 = None
D4 = Straight Ø4
D6 = Straight Ø6
D8 = Straight Ø8
L1 = Female banjo G1/8"
G4 = Rotating banjo Ø4
G6 = Rotating banjo Ø6
G8 = Rotating banjo Ø8
M1 = G1/8" male
M2 = G1/4" male
F1 = G1/8" female

Note

Example: 5512F1.00.00.XX
90° blocking valve + flow control valve.
Without connections "A" and "B".
For the dimension including cartridges
see page Accessories - Function fittings

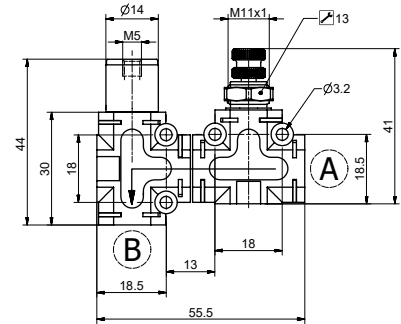

Technical characteristics

- The combination of this two functions ensures that the downstream pressure is maintained in case of accidental loss of supply pressure and at the same time grants the possibility to regulate the circuit flow rate. A typical application of this combination is close to or directly assembled onto the actuator connection ports. This allows to keep pressurised the cylinder chamber in case of accidental loss of supply pressure and to regulate the exhaust flow rate when the blocking valve is actuated.
- The possible combinations are the following:
 - 90° unidirectional blocking valve + unidirectional flow control valve
 - 90° bidirectional blocking valve + bidirectional flow control valve
 - 90° bidirectional blocking valve + unidirectional flow control valve
 - 90° unidirectional blocking valve + bidirectional flow control valve

Technical characteristics

- Fluid: **Filtered and lubricated air or non**
- Working ports size: **see connections list**
- Max working pressure: **0,5 ... 10 bar**
- Temperature: **-5 °C ... + 50 °C**
- Orifice size: **Ø3 mm**
- Flow rate at 6 bar with $\Delta p=1$ (NI/min): **285 NI/min**
- Weight: **62 g**

Piloting curves

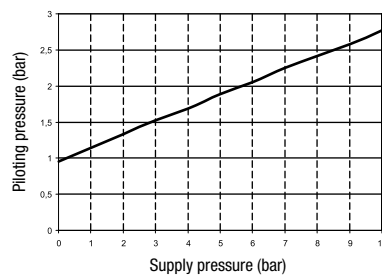

Pneumatic symbols

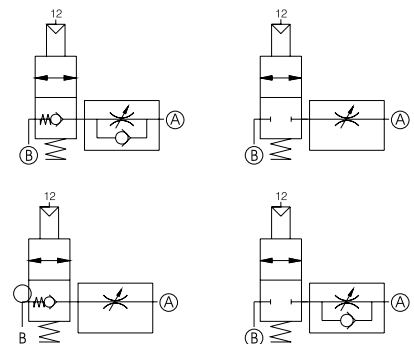

ART. 551.1GT.A.B.XX

In line blocking valve + quick exhaust valve

TYPE

T	1 = Unidirectional blocking valve + quick exhaust valve 2 = Bidirectional blocking valve + quick exhaust valve
A	Connection A - see connections list
B	Connection B - see connections list

SEE CONNECTIONS LIST

00	= None
D4	= Straight Ø4
D6	= Straight Ø6
D8	= Straight Ø8
L1	= Female banjo G1/8"
G4	= Rotating banjo Ø4
G6	= Rotating banjo Ø6
G8	= Rotating banjo Ø8
M1	= G1/8" male
M2	= G1/4" male
F1	= G1/8" female

Note:

Example: 5511G1.00.00.XX
In line blocking valve + quick exhaust valve. Without connections "A" and "B".
For the dimension including cartridges see page Accessories - Function fittings

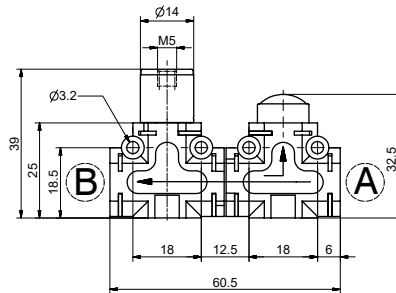

Technical characteristics

- The combination of this two functions ensures that the downstream pressure is maintained in case of accidental loss of supply pressure and at the same time allows for the air to be directly discharged into the atmosphere without going through the pneumatic circuit. A typical application of this combination is close to or directly assembled onto the actuator connection ports. This allows to keep pressurised the cylinder chamber in case of accidental loss of supply pressure and to quickly discharge the same chamber when the blocking valve is actuated.
- The possible combinations are the following:
 - Unidirectional blocking valve + quick exhaust valve
 - Bidirectional blocking valve + quick exhaust valve

Technical characteristics

- Fluid: **Filtered and lubricated air or non**
- Working ports size: **see connections list**
- Max working pressure: **0,5 ... 10 bar**
- Temperature: **-5 °C ... + 50 °C**
- Flow rate at 6 bar with $\Delta p=1$ (NI/min): **285 NI/min**
- Weight: **51 g**

Piloting curves

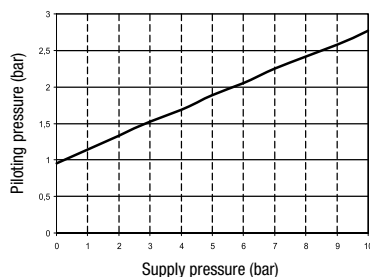

Pneumatic symbols

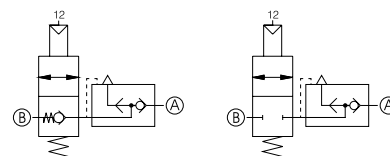

ART. **551.2GT.A.B.XX**

90° blocking valve + quick exhaust valve

TYPE

T	1 = 90° unidirectional blocking valve + quick exhaust valve 2 = 90° bidirectional blocking valve + quick exhaust valve
A	Connection A - see connections list
B	Connection B - see connections list

SEE CONNECTIONS LIST

00	= None
D4	= Straight Ø4
D6	= Straight Ø6
D8	= Straight Ø8
L1	= Female banjo G1/8"
G4	= Rotating banjo Ø4
G6	= Rotating banjo Ø6
G8	= Rotating banjo Ø8
M1	= G1/8" male
M2	= G1/4" male
F1	= G1/8" female

Note:

Example: 5512G1.00.00.XX
90° bidirectional blocking valve + quick exhaust valve. Without connections "A" and "B".
For the dimension including cartridges see page Accessories - Function fittings

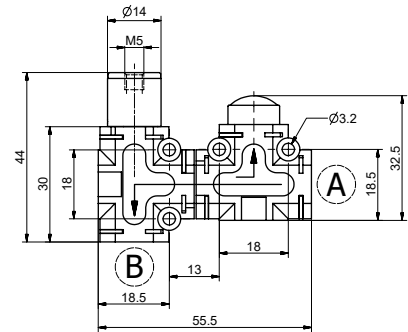
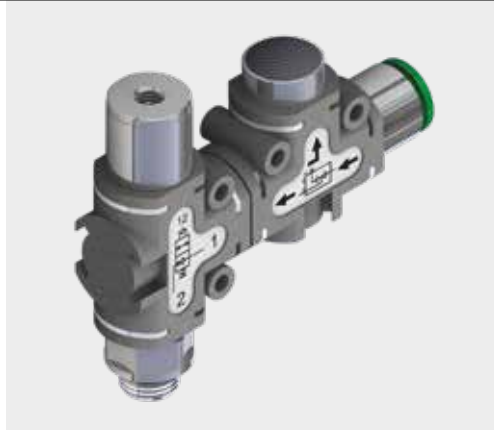

Technical characteristics

- The combination of this two functions ensures that the downstream pressure is maintained in case of accidental loss of supply pressure and at the same time allows for the air to be directly discharged into the atmosphere without going through the pneumatic circuit. A typical application of this combination is close to or directly assembled onto the actuator connection ports. This allows to keep pressurised the cylinder chamber in case of accidental loss of supply pressure and to quickly discharge the same chamber when the blocking valve is actuated.
- The possible combinations are the following:
 - 90° unidirectional blocking valve + quick exhaust valve
 - 90° bidirectional blocking valve + quick exhaust valve

Technical characteristics

- Fluid: **Filtered and lubricated air or non**
- Working ports size: **see connections list**
- Max working pressure: **0,5 ... 10 bar**
- Temperature: **-5 °C ... + 50 °C**
- Flow rate at 6 bar with $\Delta p=1$ (NI/min): **285 NI/min**
- Weight: **51 g**

Piloting curves

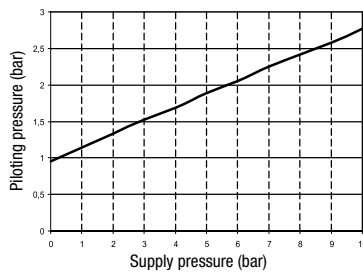

Pneumatic symbols

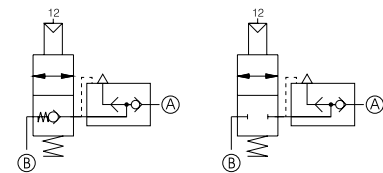

ART. 551.1HT.A.B.XX

TYPE

T	2 = 0 - 2 bar
	4 = 0 - 4 bar
	8 = 0 - 8 bar
A	Connection A - see connections list
B	Connection B - see connections list

SEE CONNECTIONS LIST

00	= None
D4	= Straight Ø4
D6	= Straight Ø6
D8	= Straight Ø8
L1	= Female banjo G1/8"
G4	= Rotating banjo Ø4
G6	= Rotating banjo Ø6
G8	= Rotating banjo Ø8
M1	= G1/8" male
M2	= G1/4" male
F1	= G1/8" female

Note

Example: 551.1H2.M1.D4.XX
In line pressure regulator, adjusting range 0 - 2 bar + pressure indicator. Connections "A" Male G 1/8 and "B" Tube Ø4.
For the dimension including cartridges see page Accessories - Function fittings

In line pressure regulator + pressure indicator

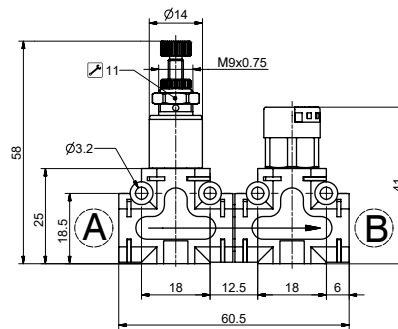

Technical characteristics

- The combination of this two functions ensures the possibility to regulate the downstream pressure while directly visualising the adjusted pressure value.
- The possible combinations are the following:
 - 0 to 2 bar pressure regulator + pressure visual indicator
 - 0 to 4 bar pressure regulator + pressure visual indicator
 - 0 to 8 bar pressure regulator + pressure visual indicator
- The visual indicator Pressure range (bar) is always 0 to 8 bar

Technical characteristics

- Fluid: **Filtered and lubricated air or non**
- Working ports size: **see connections list**
- Max working pressure: **8 bar**
- Temperature: **-5 °C ... + 50 °C**
- Visualization scale: **0 ... 8 bar**
- Pressure range: **0 ... 2 - 0 ... 4 - 0 ... 8 bar**
- Weight: **62 g**

Pneumatic symbols

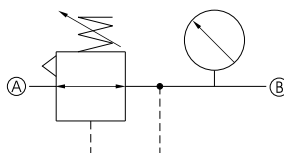

ART. 551.2HT.A.B.XX

TYPE

T	2 = 0 - 2 bar
	4 = 0 - 4 bar
	8 = 0 - 8 bar
A	Connection A - see connections list
B	Connection B - see connections list

SEE CONNECTIONS LIST

00	= None
D4	= Straight Ø4
D6	= Straight Ø6
D8	= Straight Ø8
L1	= Female banjo G1/8"
G4	= Rotating banjo Ø4
G6	= Rotating banjo Ø6
G8	= Rotating banjo Ø8
M1	= G1/8" male
M2	= G1/4" male
F1	= G1/8" female

Note

Example: 551.2H2.M1.D4.XX
90° pressure regulator, adjusting range 0 - 2 bar + pressure indicator. Connections "A" Male G 1/8 and "B" Tube Ø4.
For the dimension including cartridges see page Accessories - Function fittings

90° pressure regulator + pressure indicator

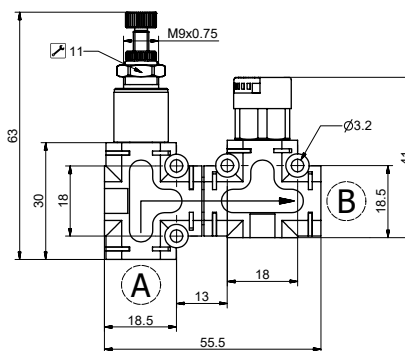

Technical characteristics

- The combination of this two functions ensures the possibility to regulate the downstream pressure while directly visualising the adjusted pressure value.
- The possible combinations are the following:
 - 0 to 2 bar pressure regulator + pressure visual indicator
 - 0 to 4 bar pressure regulator + pressure visual indicator
 - 0 to 8 bar pressure regulator + pressure visual indicator
- The visual indicator Pressure range (bar) is always 0 to 8 bar

Technical characteristics

- Fluid: **Filtered and lubricated air or non**
- Working ports size: **see connections list**
- Max working pressure: **8 bar**
- Temperature: **-5 °C ... + 50 °C**
- Visualization scale: **0 ... 8 bar**
- Pressure range: **0 ... 2 - 0 ... 4 - 0 ... 8 bar**
- Weight: **62 g**

Pneumatic symbols

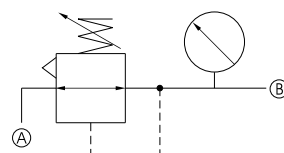

ART. **551KD4**

Straight cartridge Ø4



• Weight: 7,5 g

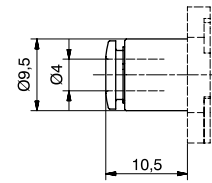

ART. **551KD6**

Straight cartridge Ø6



• Weight: 7,3 g

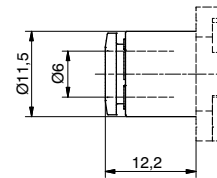

ART. **551KD8**

Straight cartridge Ø8



• Weight: 7 g

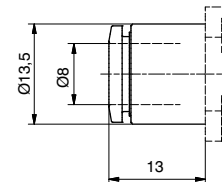

ART. **551KG4**

Banjo PL cartridge Ø4



• Weight: 13,6 g

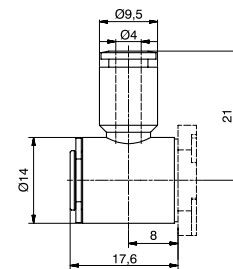

ART. **551KG6**

Banjo PL cartridge Ø6



• Weight: 14 g

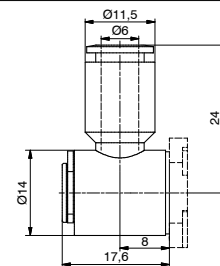

ART. **551KG8**

Banjo PL cartridge Ø8



• Weight: 13,3 g

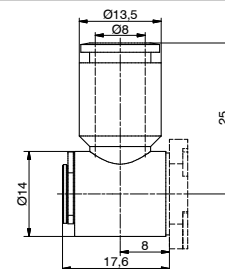

ART. **551KL1**

Banjo PL cartridge G1/8"



• Weight: 30 g

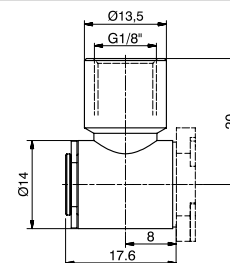

ART. 551KM1

G1/8" male straight cartridge



- Weight: 14 g

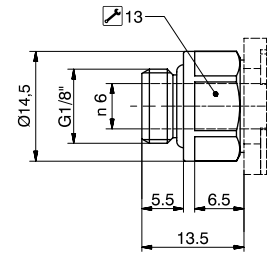

ART. 551KM2

G1/4" male straight cartridge



- Weight: 20 g

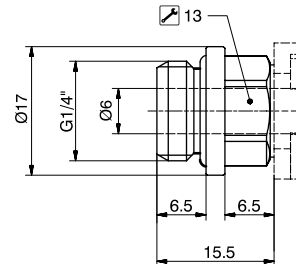

ART. 551KF1

G1/8" female straight cartridge



- Weight: 9 g

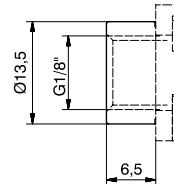

ART. 551KUU

Connection for multiple function



- Weight: 14 g

ART. 55160

Coupling kit (pins and forks)

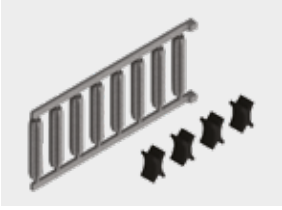

- Weight: 2,5 g

The kit, which includes a series of pins and forks, enables to join together in a fast and safe way the function fittings. The pins, once inserted in the front holes, ensure resistance against forces applied perpendicularly and sideways (for example the insertion of the tube in the cartridges). The forks, once located in the profiled housing ensures that the parts are held together tightly. The kit allows for 5 function fittings to be mounted together.

ART. 55150

Fixing brackets



- Weight: 18 g

The kit comprises two fixing brackets and screws

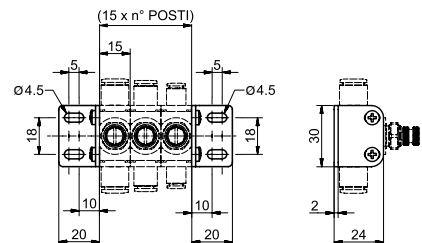

ART. 55116

DIN rail adapter



- Weight: 4 g

The kit comprises two adapters

