



Series T771 - for compressed air and vacuum in technopolymer - G1"

The range of G1" pilot and solenoid operated poppet valves represents an evolution of the current popular Zama series and of the Series T772-T773 (G1/2"-3/4").

Also for this series the main feature is the technopolymer material used to mould most of its components.

The use of this material results in a versatile, lightweight and economical valve.

This series also has other technical and functional enhancements over the existing range. Firstly, the traditional piston lip seal has been replaced with a rolling diaphragm, thereby eliminating frictional wear and tear to this seal.

This series (with the exception of certain vacuum models) also features a seal, which separates port 3 from the piston head. The inclusion of this seal has enhanced the valve's performance and allows the valve to be used as normally open (a configuration not possible in the Zama series).

Solenoid operated valves (both internal and external pilot versions) are fitted with a quick exhaust unit, which reduces the return stroke operating time by 80%.

The bulk of the valves in this series use the MP type operator, the exception being internally piloted vacuum models, which use the MV operator. These operators differ from the M2 type in that they have self-tapping mounting screws for use in plastics.

Bistable versions are also available, both for air or for vacuum. These valves are fitted with a 3/2 sol-sol valve (instead of the standard pilot valve) fitted with two 15mm 24V Dc microvalves (N331.0A).

The ordering code are referring to the solenoid valves with mechanics "MP" or "MV" assembled.

Coils are not included and have to be ordered separately (series 300, Section 1, General Catalogue), with the exception of the bistable versions which already include 24V Dc Coils (N331.0A).

Coils c  homologated are available (see 300 Series).

1
AIR DISTRIBUTION

Construction characteristics

Body, operator and end cover	High impact resistant thermoplastic
Seals and poppets	NBR
Diaphragm	Oil resistant rubber (NBR)
Springs	AISI 302 stainless steel
Piston and shaft	Acetal resin

Use and maintenance

These valves have a mean life of 10 to 15 million cycles under normal operating conditions.

Lubrication is not required for good operation but we recommend good filtration to avoid dirty deposit causing malfunction.

Please ensure that the valve is being used according with the manufacturers specification, such as air pressure and temperature.

The exhaust port of the distributor has to be protected in a dusty and dirty environment.

For these products, according to the construction technique and special application, is not required any maintenance with parts replacement.

When necessary it is sufficient to clean the internal parts.

When it is used the solenoid valves with internal pilot, either for air or vacuum, inlet flow rate must be equal or higher that the required consumption flow rate.

Otherwise is better choose the external pilot version.

MINIMUM PILOTING PRESSURE DIAGRAM (Valves for compressed air) PNEUMATIC/SPRING AND EXTERNAL SOLENOID PILOT VERSION

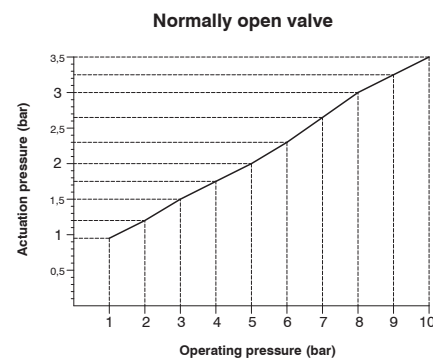
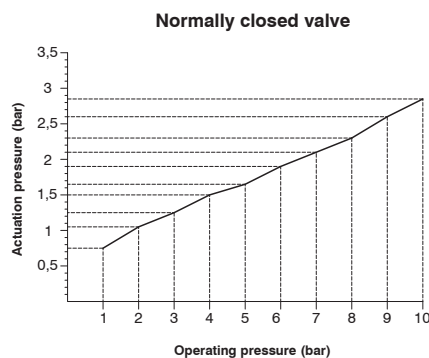



Valves and solenoid valves poppet system
Series T771 - for compressed air in technopolymer - G1"

Pneumatic - Spring

Coding: T771.32.11.1

Operational characteristics	
Fluid	filtered and lubricated air or non
Max. working pressure (bar)	10
Minimum pilot pressure (bar)	See diagram at general page
Temperature °C	-5 ... +50
Flow rate at 6 bar with $\Delta p=1$ (NI/min)	12500
Orifice size (mm)	25
Working ports size	G1"
Pilot ports size	G1/8"
Compressed air, purity class according to ISO 8573-1:2010	7:4:4

1

AIR DISTRIBUTION

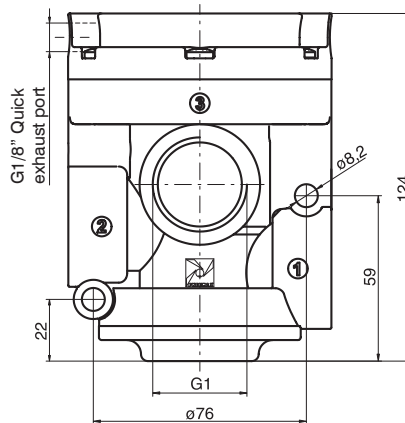
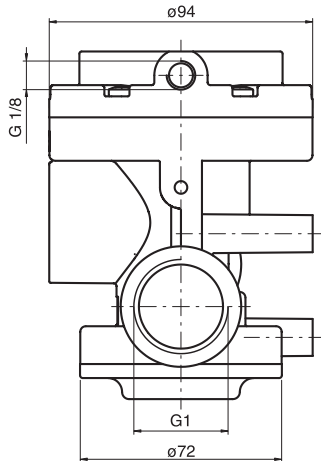

N.C.
 Inlet port 1
 Outlet port 2
 Exhaust port 3

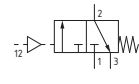

N.O.
 Inlet port 3
 Outlet port 2
 Exhaust port 1

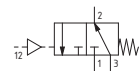

Weight 480 g

Solenoid-Spring-Internal pilot

Coding: T771.32.0.F.MP

Operational characteristics	
Fluid	filtered and lubricated air or non
Max. working pressure (bar)	10
Minimum pilot pressure (bar)	2,5
Temperature °C	-5 ... +50
Flow rate at 6 bar with $\Delta p=1$ (NI/min)	12500
Orifice size (mm)	25
Working ports size	G1"
Pilot ports size	G1/8"
Compressed air, purity class according to ISO 8573-1:2010	7:4:4

FUNCTION	
F	1AC = Normally Closed
	1AA = Normally Open

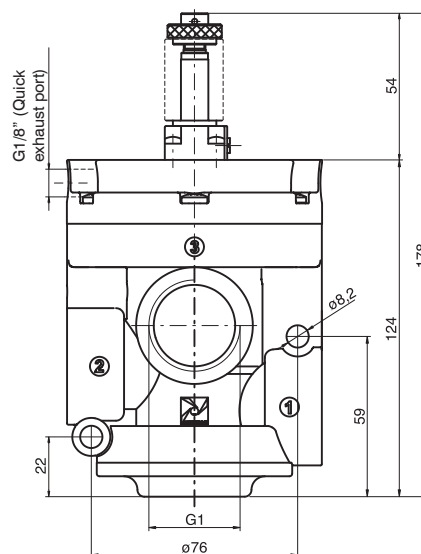
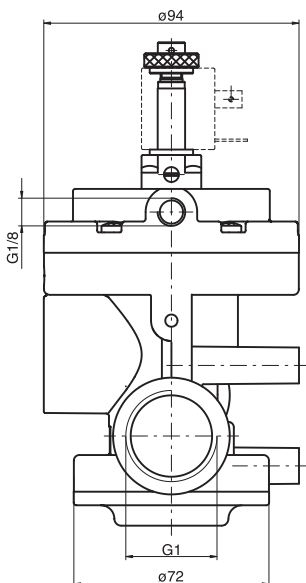

N.C.
 Inlet port 1
 Outlet port 2
 Exhaust port 3

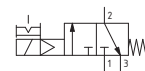

N.O.
 Inlet port 3
 Outlet port 2
 Exhaust port 1

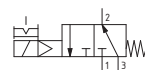

Weight 520 g

Solenoid-Spring-External pilot

Coding: T771.32.0.1.MP

Operational characteristics	
Fluid	filtered and lubricated air or non
Max. working pressure (bar)	10
Minimum pilot pressure (bar)	See diagram at general page
Temperature °C	-5 ... +50
Flow rate at 6 bar with $\Delta p=1$ (NI/min)	12500
Orifice size (mm)	25
Working ports size	G1"
Pilot ports size	G1/8"
Compressed air, purity class according to ISO 8573-1:2010	7:4:4



Weight 520 g

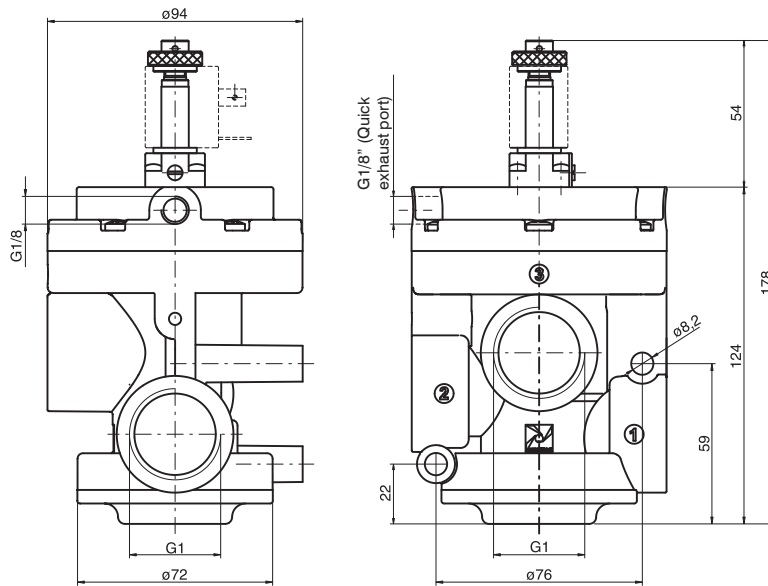

N.C.
Inlet port 1
Outlet port 2
Exhaust port 3

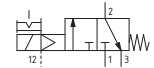

N.O.
Inlet port 3
Outlet port 2
Exhaust port 1

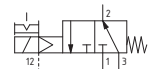

Solenoid-Spring - Internal pilot with quick exhaust

Coding: T771S.32.0.1.MP

Operational characteristics	
Fluid	filtered and lubricated air or non
Max. working pressure (bar)	10
Minimum pilot pressure (bar)	2,5
Temperature °C	-5 ... +50
Flow rate at 6 bar with $\Delta p=1$ (NI/min)	12500
Orifice size (mm)	25
Working ports size	G1"
Pilot ports size	G1/8"
Compressed air, purity class according to ISO 8573-1:2010	7:4:4



Weight 520 g

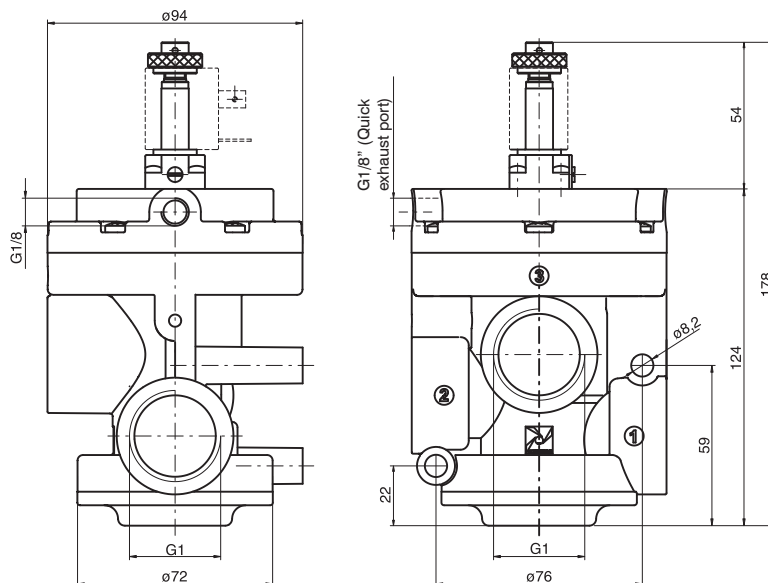

N.C.
Inlet port 1
Outlet port 2
Exhaust port 3

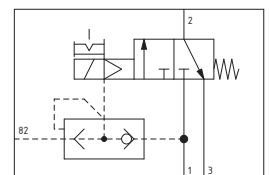

N.O.
Inlet port 3
Outlet port 2
Exhaust port 1

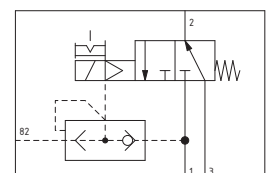



Solenoid-Spring - External pilot with quick exhaust

Coding: T771S.32.0.1.MP

Operational characteristics

Fluid	filtered and lubricated air or non
Max. working pressure (bar)	10
Minimum pilot pressure (bar)	See diagram at general page
Temperature °C	-5 ... +50
Flow rate at 6 bar with $\Delta p=1$ (NI/min)	12500
Orifice size (mm)	25
Working ports size	G1"
Pilot ports size	G1/8"
Compressed air, purity class according to ISO 8573-1:2010	7:4:4

1
AIR DISTRIBUTION



Weight 520 g

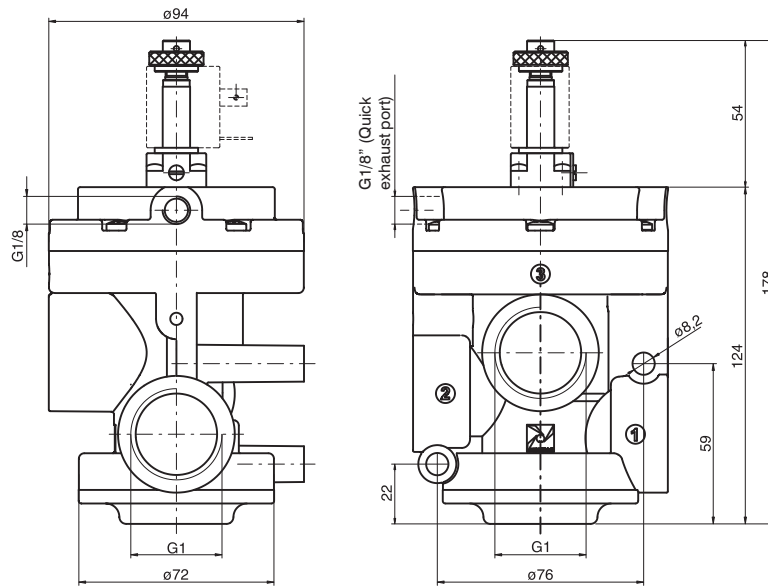

N.C.
 Inlet port 1
 Outlet port 2
 Exhaust port 3

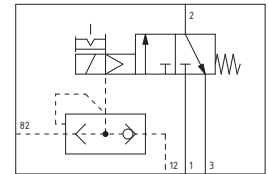

N.O.
 Inlet port 3
 Outlet port 2
 Exhaust port 1

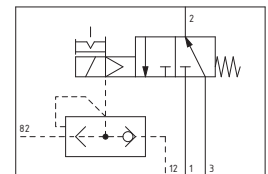

Pneumatic - Spring

Coding: T771/V.32.11.1

Operational characteristics	
Fluid	Vacuum
Minimum pilot pressure (bar)	2
Temperature °C	-5 ... +50
Orifice size (mm)	25
Working ports size	G1"
Pilot ports size	G1/8"
Response time according to ISO 12238, activation time (ms)	N.C. = 55 - N.O. = 19
Response time according to ISO 12238, deactivation time (ms)	N.C. = 320 - N.O. = 450

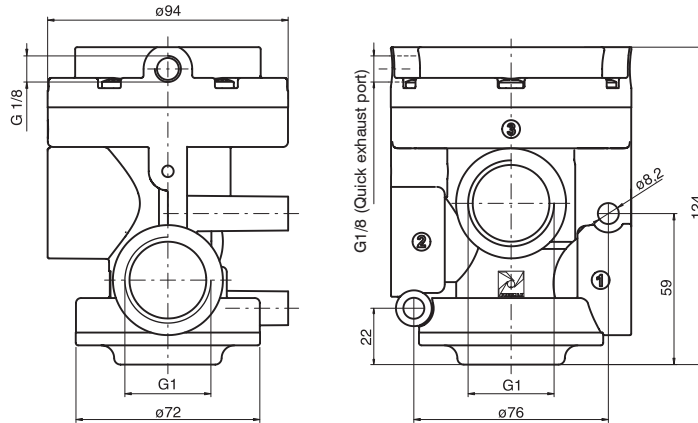

Weight 480 g

N.C.
Exhaust port 3
Outlet port 2
Pump 1

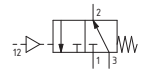

N.O.
Exhaust port 1
Outlet port 2
Pump 3

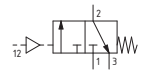

1
AIR DISTRIBUTION

Solenoid-Spring-Internal pilot

Coding: T771/V.32.0.F.MV

Operational characteristics	
Fluid	Vacuum
Temperature °C	-5 ... +50
Orifice size (mm)	25
Working ports size	G1"
Pilot ports size	G1/8"
Response time according to ISO 12238, activation time (ms)	1AC = 100 - 1AA = 80
Response time according to ISO 12238, deactivation time (ms)	1AC = 60 - 1AA = 60

FUNCTION	
F	1AC = Normally Closed
	1AA = Normally Open

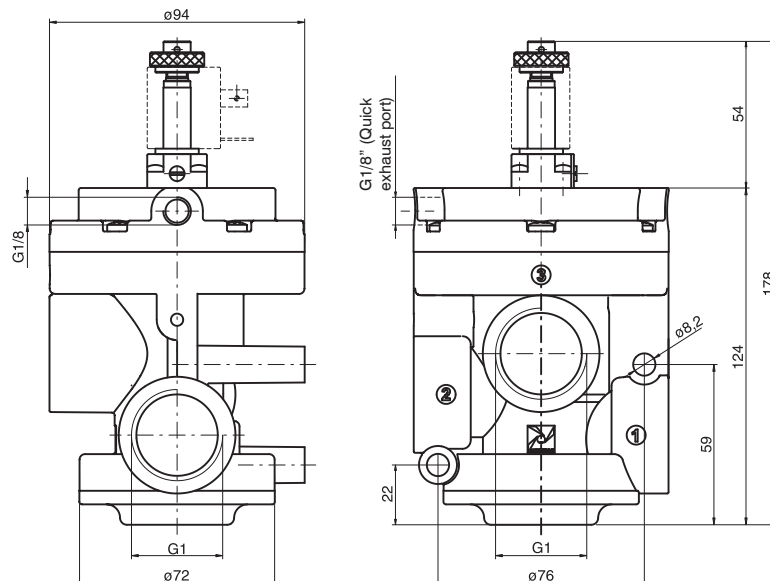

Weight 520 g

N.C.
Exhaust port 1
Outlet port 2
Pump 3

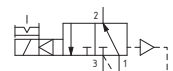

N.O.
Exhaust port 3
Outlet port 2
Pump 1





Solenoid-Spring-External pilot

Coding: T771/V.32.0.1.MP

Operational characteristics

Fluid	Vacuum
Minimum pilot pressure (bar)	2
Temperature °C	-5 ... +50
Orifice size (mm)	25
Working ports size	G1"
Pilot ports size	G1/8"
Response time according to ISO 12238, activation time (ms)	N.C. = 50 - N.O. = 19
Response time according to ISO 12238, deactivation time (ms)	N.C. = 315 - N.O. = 450

AIR DISTRIBUTION



Weight 520 g

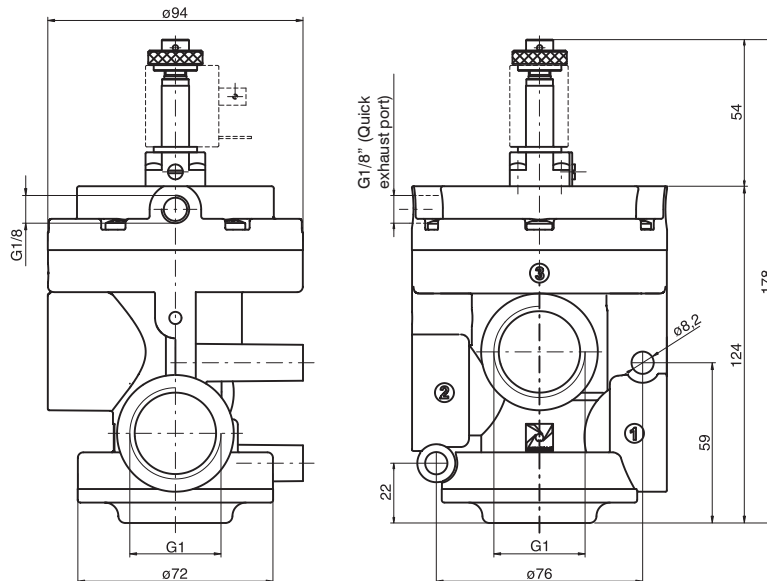

N.C.
Pump 1
Outlet port 2
Exhaust port 3

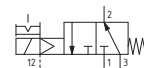

N.O.
Pump 3
Outlet port 2
Exhaust port 1

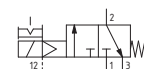

Solenoid-Spring - External pilot with quick exhaust

Coding: T771/VS.32.0.1.MP

Operational characteristics

Fluid	Vacuum
Minimum pilot pressure (bar)	2
Temperature °C	-5 ... +50
Orifice size (mm)	25
Working ports size	G1"
Pilot ports size	G1/8"
Response time according to ISO 12238, activation time (ms)	N.C. = 50 - N.O. = 19
Response time according to ISO 12238, deactivation time (ms)	N.C. = 50 - N.O. = 70



Weight 520 g

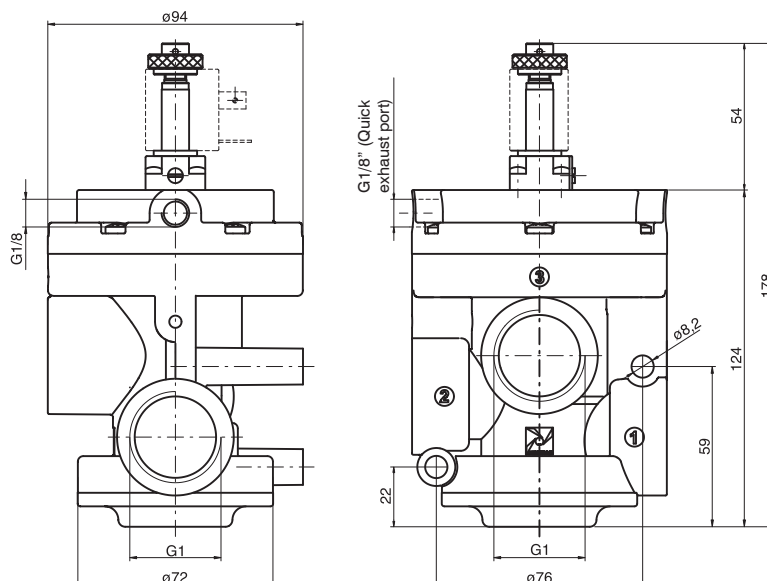

N.C.
Pump 1
Outlet port 2
Exhaust port 3

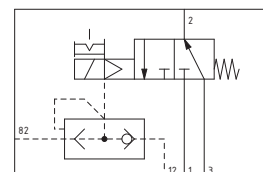

N.O.
Pump 3
Outlet port 2
Exhaust port 1

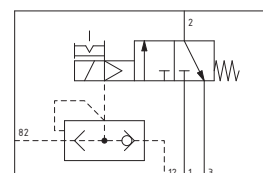

Bistable for compressed air - G1"

Coding: T771.32.0.1.BP

Operational characteristics	
Fluid	filtered and lubricated air or non
Max. working pressure (bar)	10
Minimum pilot pressure (bar)	2.5
Temperature °C	-5 ... +50
Flow rate at 6 bar with $\Delta p=1$ (NI/min)	12500
Orifice size (mm)	25
Working ports size	G1"
Pilot ports size	G1/8"
Compressed air, purity class according to ISO 8573-1:2010	7:4:4



Weight 680 g

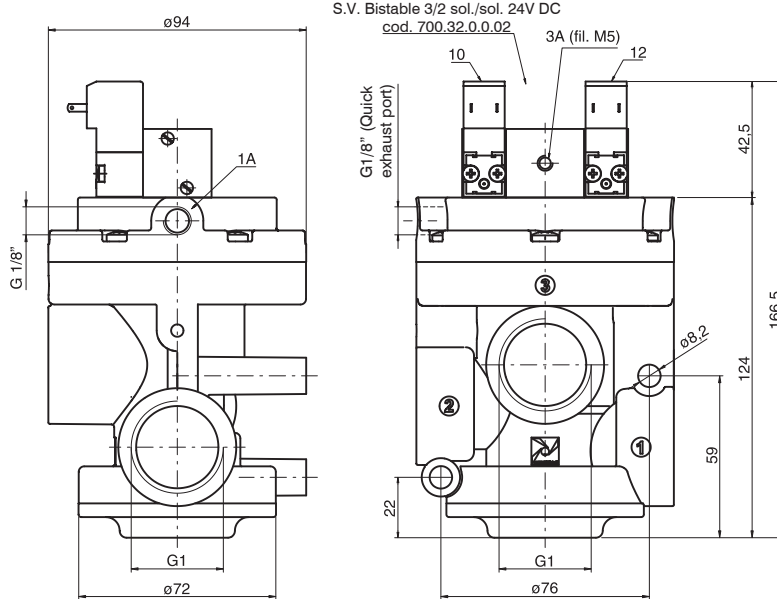

N.C.
Inlet port 1
Outlet port 2
Exhaust port 3

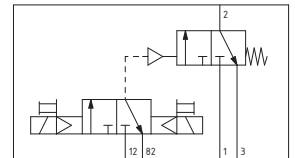

N.O.
Inlet port 3
Outlet port 2
Exhaust port 1

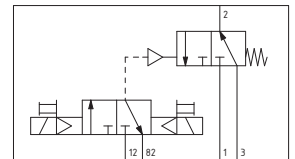

Bistable for compressed air with quick exhaust - G1"

Coding: T771S.32.0.1.BP

Operational characteristics	
Fluid	filtered and lubricated air or non
Max. working pressure (bar)	10
Minimum pilot pressure (bar)	2.5
Temperature °C	-5 ... +50
Flow rate at 6 bar with $\Delta p=1$ (NI/min)	12500
Orifice size (mm)	25
Working ports size	G1"
Pilot ports size	G1/8"
Compressed air, purity class according to ISO 8573-1:2010	7:4:4



Weight 680 g

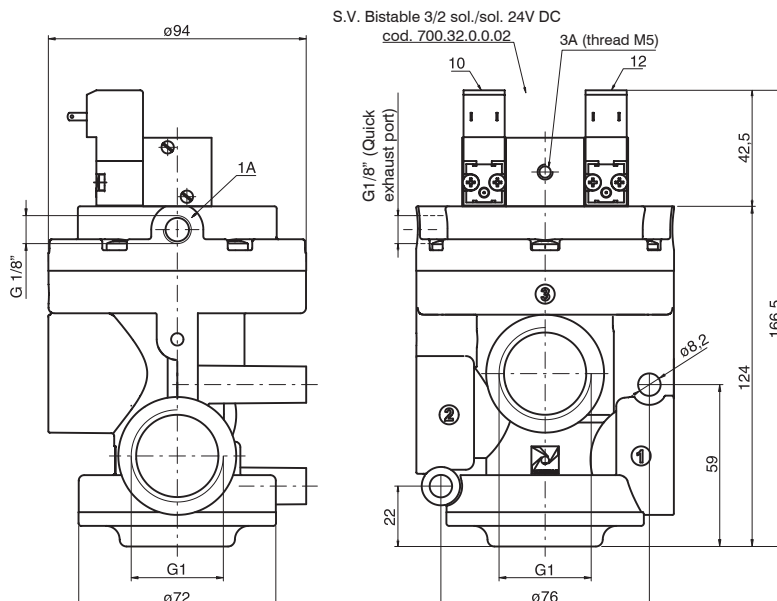

N.C.
Inlet port 1
Outlet port 2
Exhaust port 3

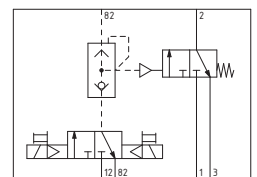

N.O.
Inlet port 3
Outlet port 2
Exhaust port 1

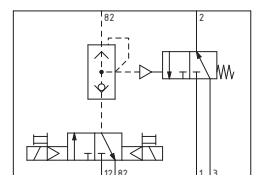



Bistable for vacuum - G1"

Coding: T771/V.32.0.1.BP

Operational characteristics	
Fluid	Vacuum
Minimum pilot pressure (bar)	2,5
Temperature °C	-5 ... +50
Orifice size (mm)	25
Working ports size	G1"
Pilot ports size	G1/8"

1
AIR DISTRIBUTION



Weight 680 g

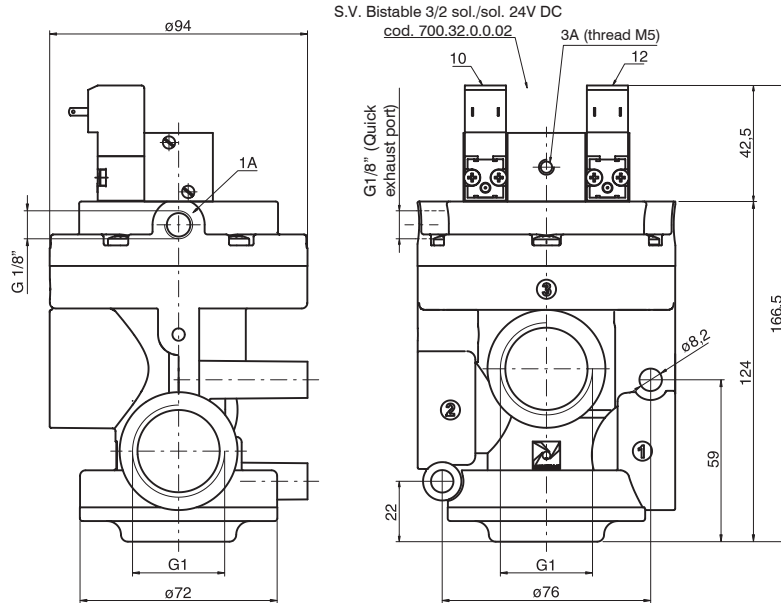

N.C.
 Pump 1
 Outlet port 2
 Exhaust port 3

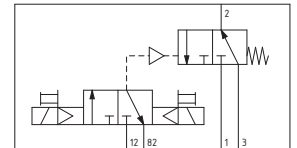

N.O.
 Pump 3
 Outlet port 2
 Exhaust port 1

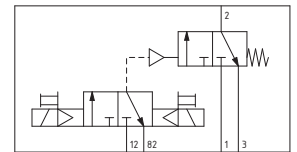

Bistable for vacuum with quick exhaust - G1"

Coding: T771/VS.32.0.1.BP

Operational characteristics	
Fluid	Vacuum
Minimum pilot pressure (bar)	2,5
Temperature °C	-5 ... +50
Orifice size (mm)	25
Working ports size	G1"
Pilot ports size	G1/8"



Weight 680 g

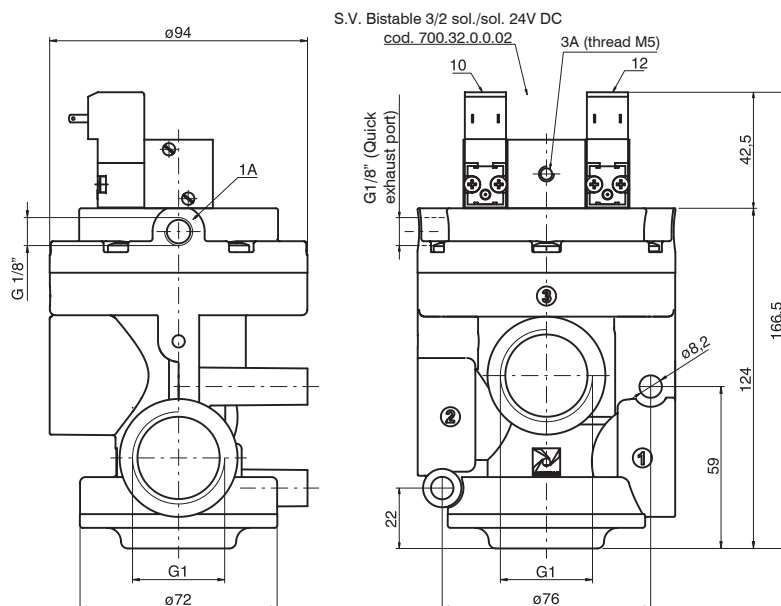

N.C.
 Pump 1
 Outlet port 2
 Exhaust port 3

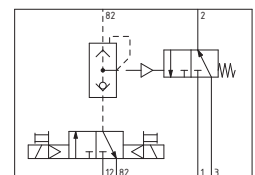

N.O.
 Pump 3
 Outlet port 2
 Exhaust port 1

